

# DPA

DANSK  
PRODUCENT  
ANSVAR

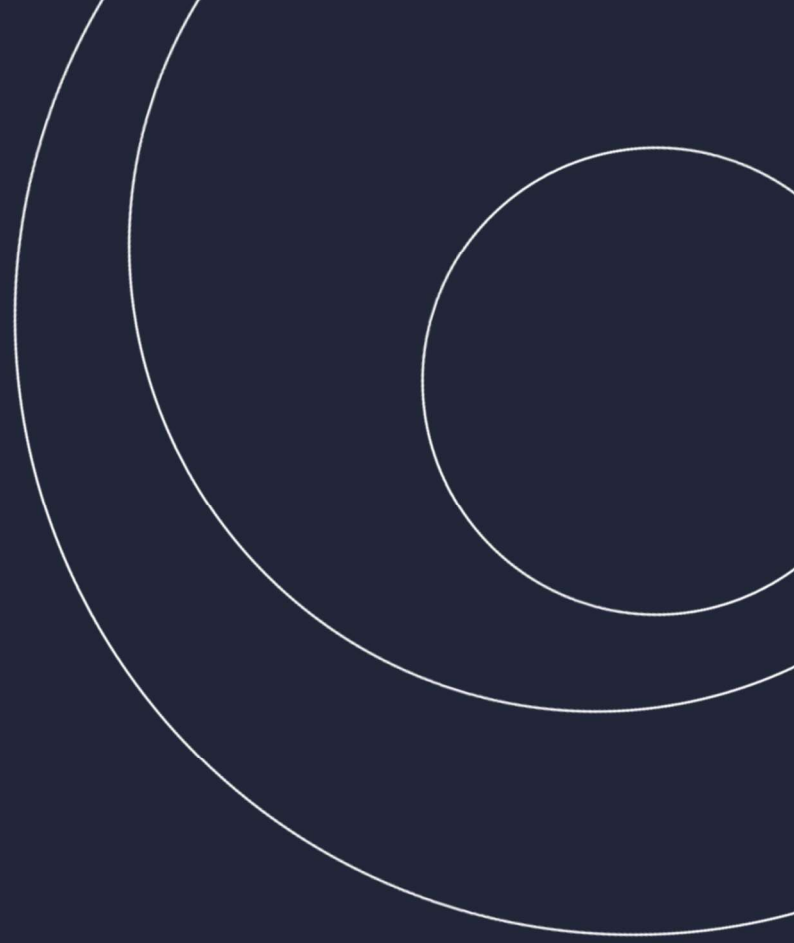

# Marking of equipment (WEEE)

Dansk Producentansvar, November 2022

DPA is short for Dansk Producentansvar (Danish Producer Responsibility). DPA oversees administrative tasks associated with the rules on producer responsibility under the Danish environmental law regarding waste from electrical and electronic equipment, end-of-life batteries and accumulators, and end-of-life vehicles.

The producer responsibility for these waste types has authority in the Danish Environmental Protection Act. This Act translates into three Statutory Orders for the different waste types: the WEEE Order, the Battery Order, and the End-of-life Vehicles Order (the current statutory texts can be found on [www.producentansvar.dk](http://www.producentansvar.dk)).

The Danish Statutory Orders take offset in three EU directives for the same waste types: the so-called WEEE Directive, the Batteries Directive, and the ELV Directive. Also, these directives with exact titles and dates can be found on [www.producentansvar.dk](http://www.producentansvar.dk).

Producer responsibility rests on the principle that each producer or importer assumes responsibility for collection and management of WEEE, waste batteries, and end-of-life vehicles to the effect that products becoming waste are managed in an environmentally correct manner, with the highest possible utilisation of resources contained in such products.

Producers and importers are in the following referred to as producers as the rules applying to both types are the same.

In general, the following abbreviations are used: WEEE for waste electrical and electronic equipment, BAT for batteries and accumulators, and ELV for end-of-life vehicles.

In pursuance of the rules of producer responsibility for WEEE, waste batteries and ELV, this document describes the rules for marking of EEE and producer information for consumers.

# Content

Marking .....	3
Standard text for consumers .....	4

## Marking

Producers and importers must mark their products with a symbol of a crossed-out wheeled bin and in other ways inform users about management of WEEE. The symbol indicates that collection of electrical and electronic equipment must not take place together with ordinary domestic waste and that it must be treated as WEEE. Name or brand of the producer must be placed on the product in a way that allows for identification of the producer.

Marking must comply with the symbol shown in Annex V to the WEEE Order or the standard DS/EN 50 419: Marking of electrical and electronic equipment. This standard applies to equipment for both professional and private use.

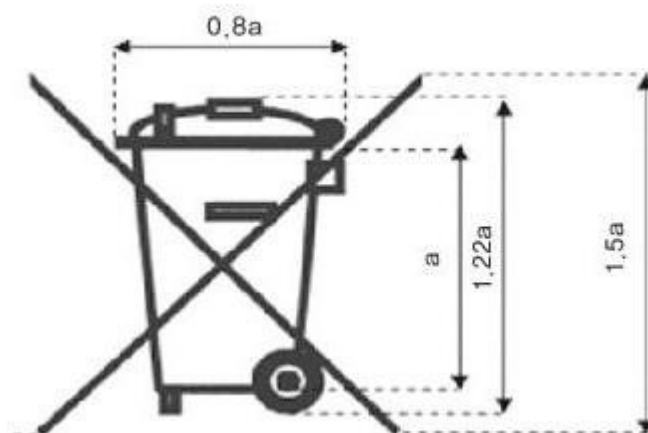

Name or brand of the producer or the importer must always be found on the product (equipment). The crossed-out wheeled bin symbol can in certain cases, such as very small equipment, be printed in the operating instructions on the warranty certificate or the packaging, and thus not on the product.

The standard states that the size of the wheeled bin symbol must be at least 7 mm to be legible. The producer may choose to emboss the symbol onto the product, print it or use stickers. The standard also contains procedures for testing of durability: rubbing by hand for 15 seconds with a piece of cloth soaked with water and again for 15 seconds with a piece of cloth soaked with petroleum spirit. After this, the marking must be legible. The bar in the lower part of the symbol must not contain any text or any kind of additional information.

**In general, the marking shall be accessible, durable, legible and indelible.**

On the website of Danish Standards [www.ds.dk](http://www.ds.dk) you can find files for reproduction of the symbol. Producers are responsible for production of the symbol with a printing shop or similar.

The rules of marking are stipulated in section 49 of the WEEE Order. The Danish Environmental Protection Agency oversees compliance control.

The rules of marking of equipment with the crossed-out wheeled bin symbol and producer/importer brand came into force in Denmark on 13 August 2005. All equipment produced after this date must be marked with this symbol.

### Black bar or not

If your product has been placed on the market after 13 August 2005, you can either:

- specify the date that the product was placed on the market
- add a bar underneath the crossed-out wheeled bin symbol.

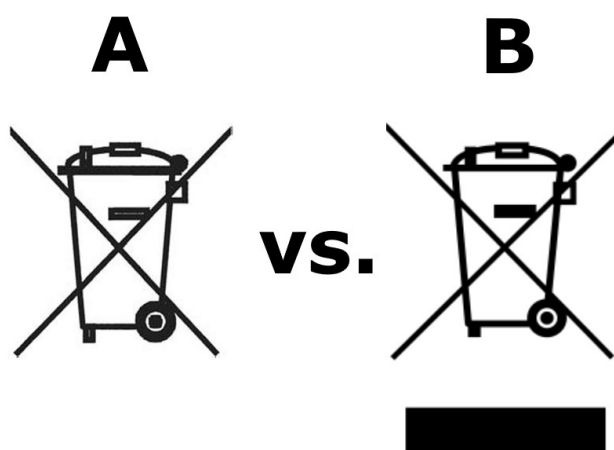

## Standard text for consumers

The Danish Environmental Protection Agency has prepared a standard text that producers of equipment destined for private use can use to explain marking and WEEE rules to consumers.

*"Elektrisk og elektronisk udstyr (EEE) indeholder materialer, komponenter og stoffer, der kan være farlige og skadelige for menneskers sundhed og for miljøet, når affaldet af elektrisk og elektronisk udstyr (WEEE) ikke bortskaffes korrekt.*

*Produkter, der er mærket med nedenstående overkrydsede skraldespand, er elektrisk og elektronisk udstyr. Den krydsede skraldespand symboliserer, at affald af elektrisk og elektronisk udstyr ikke må bortskaffes sammen med usorteret husholdningsaffald, men skal indsamles særskilt.*

*Til dette formål har alle kommuner etableret indsamlingsordninger, hvor affald af elektrisk og elektronisk udstyr gratis kan afleveres af borgerne på genbrugsstationer eller andre indsamlingssteder eller hentes direkte fra husholdningerne. Nærmere information skal indhentes hos kommunens tekniske forvaltning.*

*Brugere af elektrisk og elektronisk udstyr må ikke bortskaffe affald af elektrisk og elektronisk udstyr sammen med husholdningsaffald. Brugere skal benytte de kommunale indsamlingsordninger for at mindske den miljømæssige belastning i forbindelse med bortskaffelse af affald af elektrisk og elektronisk udstyr og øge mulighederne for genbrug, genanvendelse og nyttiggørelse af affald af elektrisk og elektronisk udstyr".*

### English translation for information:

*"Electrical and electronic equipment (EEE) contains materials, components and substances that may be hazardous and present a risk to human health and the environment when waste electrical and electronic equipment (WEEE) is not handled correctly.*

*Equipment marked with the below crossed-out wheeled bin is electrical and electronic equipment. The crossed-out wheeled bin symbol indicates that waste electrical and electronic equipment should not be discarded together with unseparated household waste, but must be collected separately.*

*For this purpose all local authorities have established collection schemes under which residents can dispose waste electrical and electronic equipment at a recycling centre or other collection points, or WEEE will be collected directly from households. More detailed information is available from the technical administration of the relevant local authority.*

*Users of electrical and electronic equipment must not discard WEEE together with household waste. Residents must use the municipal collection schemes to reduce adverse environmental impacts in connection with disposal of waste electrical and electronic equipment and to increase opportunities for reuse, recycling and recovery of waste electrical and electronic equipment".*

### Useful information:

Danish Standards: [www.ds.dk](http://www.ds.dk) where DS/EN 50 419:2006: Marking of electrical and electronic equipment can be purchased.

Dansk Producentansvar, 2022

Vester Farimagsgade 3, 2.  
DK-1606 Copenhagen V, Denmark  
Tel: +45 3915 5161

E-mail: [info@producentansvar.dk](mailto:info@producentansvar.dk)

Web: [www.producentansvar.dk](http://www.producentansvar.dk)